

● **Slide Switch CAUTIONS**

A. Operating Stroke Setting

1. For a normally closed (NC), the driving mechanism should be set to the free position (FP). The operating mechanism should be set to the lowest switch operating position (OP) on the drawing and no lower than the end position (EP) of the switch.

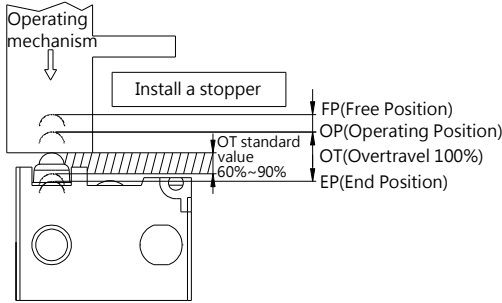

2. If stroke is set too close to the operating position (OP) and the release position (RP), this might cause unstable conductivity and result to the switch action too sensitive to vibration or shock.

3. If stroke is set over the end position (EP), the switch body may damage as well as actuator. This is also harmful to the internal moving blade, it may cause the durability of snap switch deteriorated.

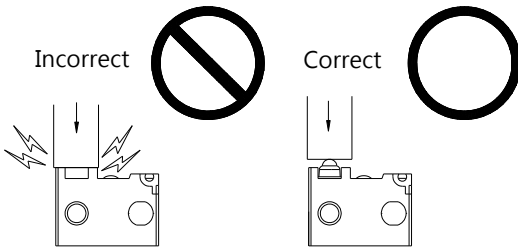

B. Operating speed and Frequency :

The operating frequency and operating speed impact the performance of the switch directly. Please pay attention to the followings:

- If the actuator is operated too slow, the changing-over of the contacts might be unstable and caused the failure in function.
- If the actuator is operated extremely high speed, the switch may be damaged by shock.
- An extremely high activation frequency may cause unstable changing-over.
- An extremely low activation of frequency (eg: once per month) may cause conductivity failure due to oxidization of the metal conductor.

The specification for switching speed and switching frequency of a switch indicates the operational reliability. The durability of a switch is based on the operation under certain specific conditions of the switching speed and switching frequency. The switch may not meet the durability due to other conditions even if the switch is operated within the permissible switching speed and frequency ranges. So, please test switch before using.

C. Using switch :

Please avoid depressing button for a long time. If the application requires the function, please contact us.

Depressed button for a long time might cause internal component deteriorated and switch characteristics various.

The travel of the actuator to the switch lever is a factor of the wear off the lever. Hence, a regular inspection is necessary.

D. Operating Method

The way of operation of the switch affects the performance of the switch.

- Avoid uneven weight on the switch lever during operation. Partly wear off of the actuator can lead to internal structures damaged and decreased reliability.

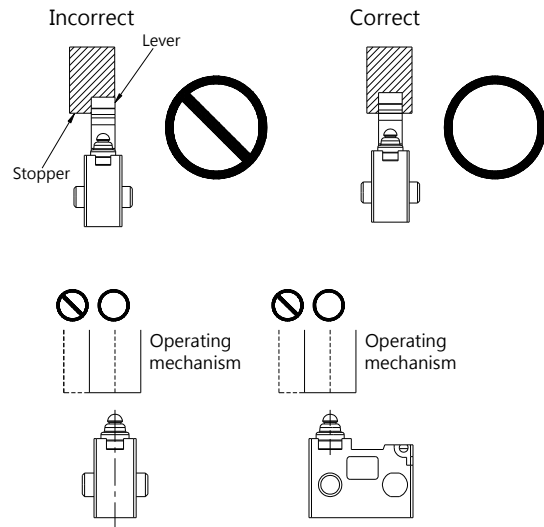

- Please press the switch button vertically

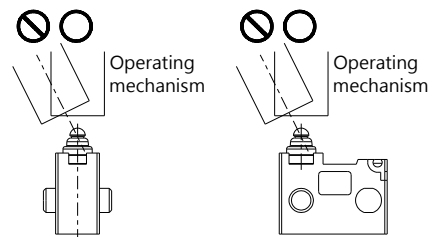

- For simulated roller lever, please follow below instructions:

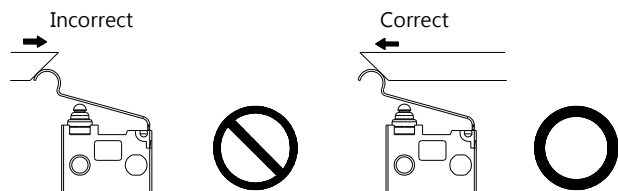

- Set the cam and plunger angles from the range of 30° to 45° .
If angle is over this range, the horizontal stress will be applied to the lever.

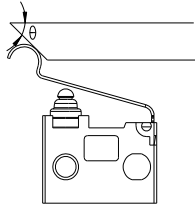

- Do not modify the lever (actuator). By doing this, excessive external force will be applied to the internal structure of the switch. It will cause the switch malfunction.
- If an external actuator is used as the actuating mechanism, please make sure that material, lever thickness and force must conform to the operating force of switch.
- If the mechanism (cam, plunger) is used in slide of pushing button, please set the angle at 20 degree and set the test speed rate at 30mm/sec. The operating position should be 0.2~0.3mm higher than end position (EP) to avoid switch damage. Please check with sales team for angle of direction, activation rate and activation frequency.

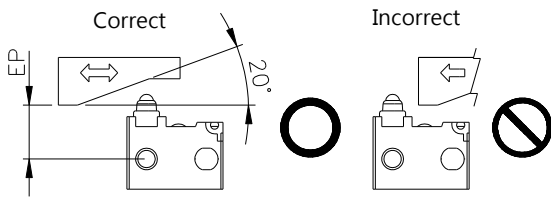

- For switch mounting hole and lever direction, please follow below instructions:

To ensure the best performance of the switch, when handling/installing the switch, please do not apply uneven pressure to the direction indicated (see below photo). Any uneven pressure or pressure direction other than the operating direction might be harmful or damage to the switch performance.

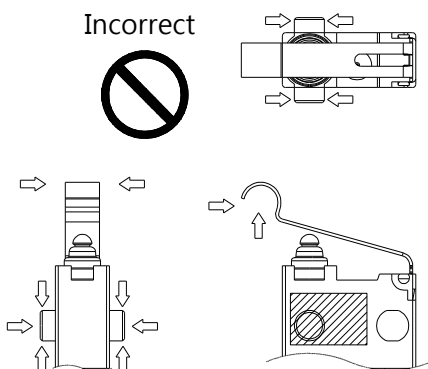

E. Switch installation

1. Securing method

When switch is fixed on the mounting hole, please use specified mounting screw for each micro switch. It is recommended to use flat washer and spring washers at the same time. If the spring washer is locked directly to the plastic surface, the spring washer could damage plastics surface. If using electric screwdrivers, please do not over-tightening or over-torqueing. This could damage switch structure.

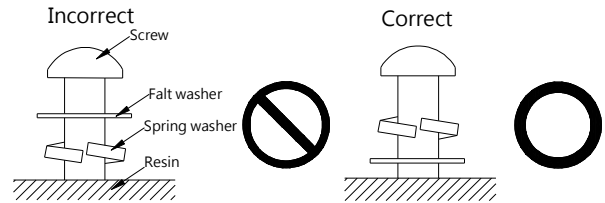

- If mounting hole diameter is $\Phi 3.20$, please use M3 screw to fix on the board. Please use spring washer and flat washer to tighten the switch on the board. **The torque value does not exceed 0.29N · m**

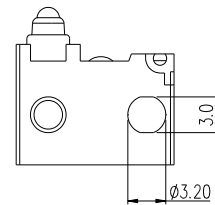

2. Locking agent for screws

While using adhesives and screw fixing agents, etc., please avoid sticking to the movable part of the switch. It could be penetrating into the inside of switch and cause the failure in switch functioning. Also, some types of locking agent will produce toxic gas and will cause switch failure. Please be careful to select locking agent.

3. Wiring method

When wiring, do not pull wire. Any wire pulling is not recommended .

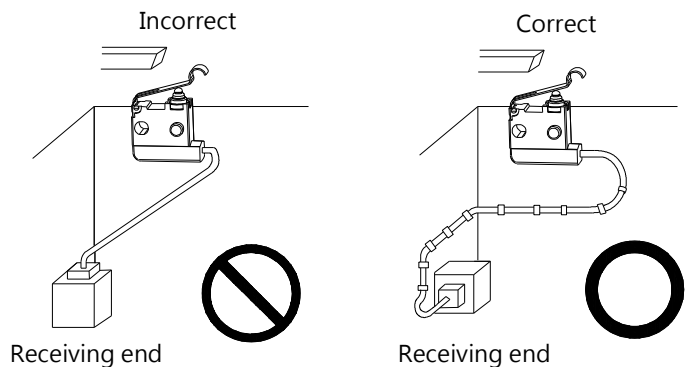

•< Important >To prevent deterioration of reliability, fork terminals should not be deformed in any situation. In order to prevent the deformation of the fork terminals, please use a special tooling to keep the switch vertical to the actual equipment. When inserting the fork terminal to the actual equipment, please make sure the fork terminal is well-supported , please follow below figure:

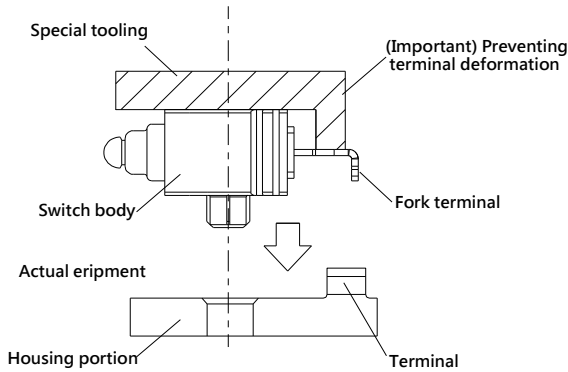

F. Operation and Storage Environment

1. Operation :

- Do not use grease on plunger and auxiliary actuators .The grease may cause micro switch operating failure and contact failure.
- Please do not damage the switch waterproof silicone While using the switch.
- Please avoid any grease, gas, chemicals gas or chemicals closed to the silicone rubber.
- <Notice>Fork terminals are not designed for soldering. Please do not solder wires with these terminal types.
- < Important > The contact reliability may highly deteriorate due to unmatched materials or inaccurate of the connection between fork terminal and the matting equipment. Please contact your Zippy representative before using fork terminal type switch.
- <Suggestion> After the installation of the switch, please seal the terminal part properly to prevent the deterioration of the contact reliability due to vibration, impact, humidity and gas. Before the sealing process, please make sure the fork terminal fixed on the equipment. Please select a sealing material that does not cause sulfuration, oxidation or generation of low molecular siloxane gas.

2. Storage Environment

- Please avoid to store switch in a place where has corrosive gas, high temperature, high humidity and high dust. For switches that have been manufactured for 3 months or more, it is recommended to test micro switch before using. Unused products must be well sealed and packed.
- Storage temperature is recommended to be in the range from 5°C~35°C. Average relative humidity is below 50% · the maximum humidity is 60% . Make sure that storage environment is without condensation and sulfide.
- To avoid *discoloration* of terminal (sulfurization), please store the *switches* in a proper bag or other suitable airtight container without sulfide.

G. Soldering

Precautions for soldering:

1. Automatic Soldering

Please do not soak the board during washing, it might can cause flux to enter the interior of the Switch, with adverse effects on Switch performance.

2. Soak soldering

- Please refer to above graphic · soak during is no longer than 2 seconds.
- Please avoid flooding the top surface of the printed circuit board with flux. Use a brush to apply flux to reduce flux penetration.

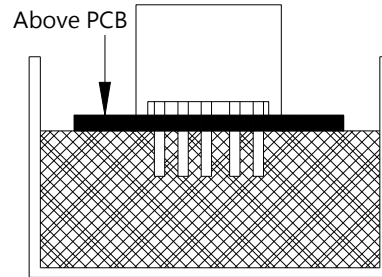

3. Cleaning of the printed circuit board

- Please refer to below graphic 1 to clean the flux, tilt the switch below 80° and clean the back with a brush soaked in solvent.

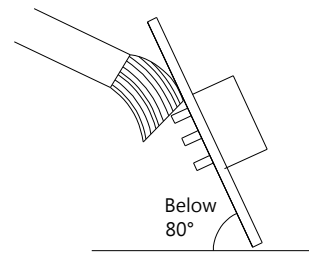

4. PCB Terminal

- PCB layout dimensions for switch PCB terminal should be 0.15~0.6 mm larger than switch terminal.
- Do not apply pressure and impact to the PCB terminals, and avoid dropping the switch, which may cause the terminals to deform and break.
- Should switch is installed on PC board, please use PCB terminals.

5. Manual Soldering

- While use soldering iron , the temperature is Max. 260°C within 5 seconds (PCB thickness more than Min 1.6mm).
- Please avoid soldering flux and alcohol penetrating into the switch.
- Do not apply external force to the terminals during soldering. Also, do not apply external force to the terminals within 3 minutes after soldering. This may cause conductivity failed or malfunction.

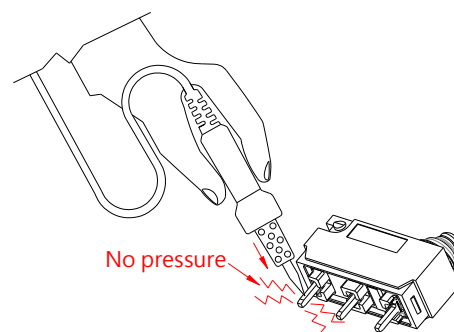

●滑動開關注意事項

A.開關操作行程設定：

1.安裝開關時務必注意，開關釋放時，務必將作動機構設定為使開關按鈕返回自由位置（FP）。

另外，開關作動時，務必將作動機構設定為超過開關動作位置（OP）下限，且不能超過結束位置（EP）。

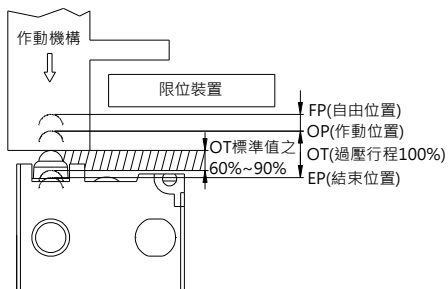

2.若機構動作位置設定在（OP）及復歸位置（RP）附近時，會導致接觸力不穩定，無法保持高可靠性，且容易因振動或衝擊發生誤觸動作。

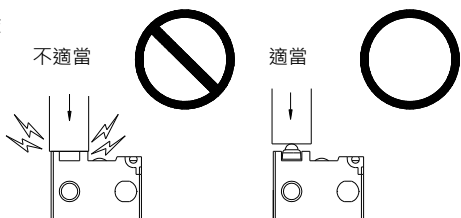

3.動作位置設定若超出限度位置（EP）時，除了會因作動機構的慣性力道導致開關按鈕或開關主體損壞之外，由於對內部可動彈簧（彈片）的施加應力過大，可能會使開關耐久性降低。

B.開關操作速度及操作頻率：

操作頻率及操作速度設定會影響開關的性能。請注意以下內容。

- 操作速度非常緩慢時，接點切換將不穩定，可能發生接觸不良或熔接等情況。
- 操作速度過快時會變為衝擊動作，可能導致提早損壞。
- 操作頻率過高，導體可能無法跟隨切換。
- 操作頻率非常低時（1次以下/月），導體表面會產生皮膜，可能造成接觸不良。

另外，規格定義操作速度、容許操作頻率代表開關的可靠性。

開關的耐久性為特定操作速度下的數值，即使規格位於容許操作速度 / 頻率範圍之內，仍可能因其條件無法滿足耐久性，故請事先試驗驗證。

C.開關使用狀態：

請盡量避免長期處於按壓的狀態使用，如需使用請洽業務單位詢問因為長期按壓會造成零組件提早劣化，特性產生變化。

此外，在使用凸輪或擋塊接觸於開關的壓柄（滾輪）的狀態下移動時，滾輪或滾輪軸的磨損量會隨著移動距離增長而變大，因此請實施定期檢查及更換。

D.開關的操作方法

開關的操作方法會影響開關的性能。請注意以下內容並進行操作。

- 操作時避免開關壓柄承受不均勻的重量。局部磨耗會導致驅動結構損壞，耐久性降低。

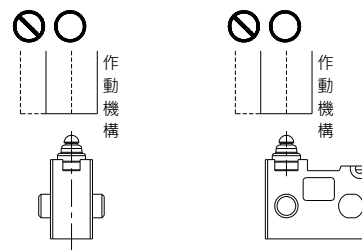
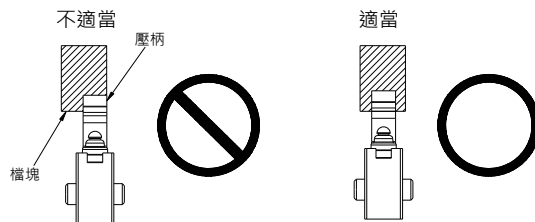

- 配合開關按鈕動作方向操作，請垂直按下開關按鈕。

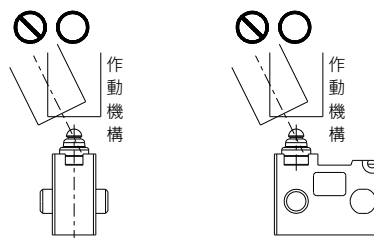

- 使用 R 型壓柄請依照下圖方向操作。

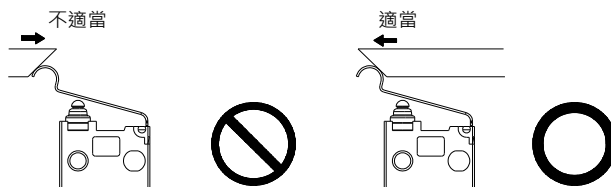

- 相對於R型壓柄等的凸輪、擋塊角度請設定在30~45°的範圍，角度過大會對壓柄施加異常橫向應力。

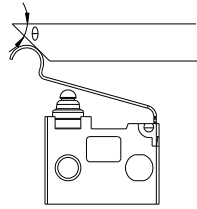

- 若對開關壓柄進行自行加工，會對開關內部結構施加多餘外力，導致特性變化或開關無法發揮功能。
- 若使用外接壓柄作為作動機構時，請確認使用的材質、板厚，施加的荷重需符合開關的操作荷重。

- 搭配於開關的機構(凸輪、擋塊)，使用於側向推動開關按鈕的方式，角度請設定在20°，測試速率請設定為30mm/sec，測試頻率請設定為Max.20次/min，動作位置設定，需高於限度位置(EP) 0.2~0.3mm，以避免對按鈕施加過大的衝擊，造成開關損壞
- *如側向推動角度、測試速率、測試頻率不同，請洽業務單位詢問。

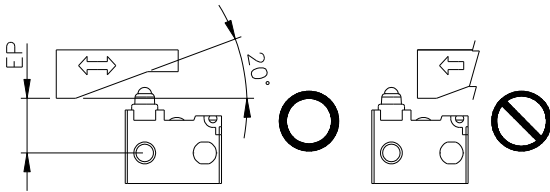

- 開關定位柱或各式壓柄請避免依照下圖方向操作。
- 為確保開關正常運作，安裝及取用開關時，請勿直接施加壓力在圖中箭頭所指示的方向。如圖所示，任何不對稱的壓力或作動方向以外的壓力都不適用在開關壓柄或定位柱上。

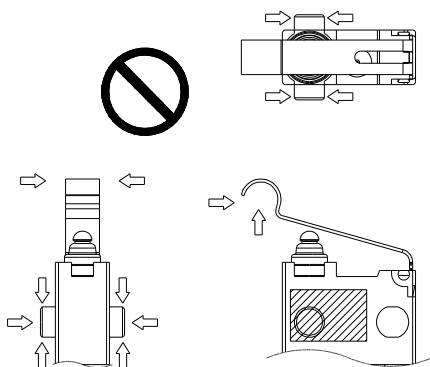

E. 安裝方法

- 開關固定方式

安裝開關時，請使用各開關指定的安裝螺絲，建議同時使用平墊圈、彈簧墊圈，如果直接將彈簧墊圈靠在塑膠面上鎖緊時，彈簧墊圈會陷入塑膠並使其產生裂縫，因此請依照下圖配置，將平墊圈靠在塑膠面上。另外，鎖緊螺絲時，如使用電動起子等工具時，會對開關施加過大的衝擊或扭力，有可能造成接點沾黏或開關損壞，敬請務必注意。

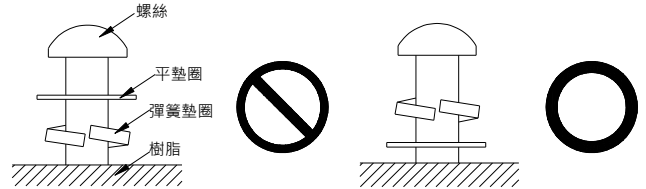

- 若使用孔徑 $\Phi 3.2\text{mm}$ 定位孔型式上蓋，請使用M3小型螺絲固定在平面上，並使用平墊圈或者彈性墊圈以便安全的鎖固開關，鎖固扭力請勿超過 $0.29\text{ N}\cdot\text{m}$ 。

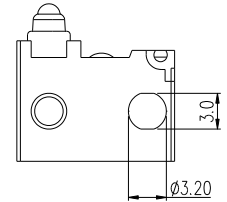

- 螺絲固定劑等的使用

使用接著劑、螺絲固定劑等時，請避免沾附於開關可動部位或滲入內部。否則可能造成動作異常、接觸障礙。另外，某些種類會產生有毒氣體，造成不良影響，選用時請充分確認。

- 配線方法

配線時，請勿對導線施加拉扯的力量。

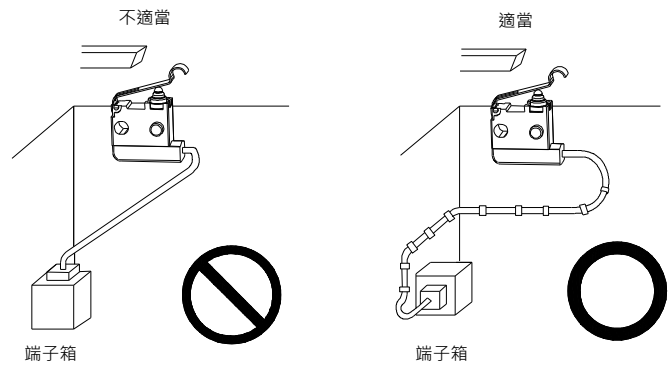

- <重要> 為防止叉形端子變形而導致接觸可靠性下降，應使用專用工具安裝叉形端子開關，以使其保持垂直於實際設備的狀態，並在支撐端子的同時插入端子，建議安裝方式請參照下圖

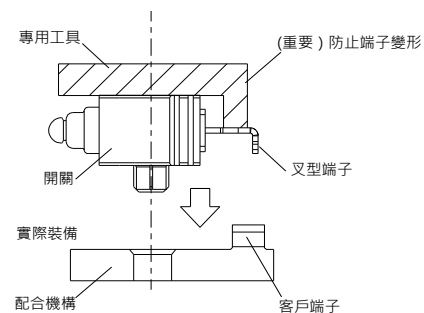

●使用、儲存環境

A.操作事項

- 按鈕、各式壓柄部位等作動部分請勿上油，否則可能造成動作異常、接觸不良。
- 使用開關時，請勿損壞開關防水矽膠罩及開關防水膠。
- 請避免沾附油脂、油氣、化學氣體及化學物質在開關的矽膠防水罩上。
- 請注意，叉形端子型式並不適用於焊線或焊接。
- <重要> 由於使用不匹配的材料或叉形端子與設備裝配不精準，端子連接部分的接觸可靠性可能會大大降低。如果您考慮使用叉形端子類型，請務必諮詢我們
- <建議> 在端子部上使用密封材料，將開關完全固定並密封端子部，以防止由於開關的叉形端子和實際設備的端子因振動、衝擊、潮濕和氣體而導致連接部分的接觸可靠性下降。（切勿使用未密封的開關）此外，有必要選擇不會引起硫化、氧化或低分子矽氧烷氣體生成的密封材料，因為存在因密封材料而導致接觸失敗的風險。為了選擇密封材料，應事先通過實際設備進行充分驗證。

B.關於儲存環境

- 請避免放置於會產生腐蝕性氣體的場所或高溫、高濕、高粉塵的場所。依儲存場所不同，超過製造日期3個月或更長時間的開關，建議使用前請再次檢查，未使用完的產品必須密封包裝。
- 開關儲存條件，溫度介於 5°C~35°C之間，平均相對溼度低於 50%，最大溼度上限為 60%，無冷凝和含硫環境。
- 儲存開關時，為防止端子（鍍銀）因硫化導致變色，請勿放入含硫包裝內保存。

G.焊接

焊接PCB板時請注意以下幾點：

1.自動焊接

- 請勿採用浸泡清洗，會使焊劑滲入到開關內部，可能會導致接觸不良。

2.浸焊

- 在進行塗抹焊劑作業時，如圖所示，浸泡時間最多2秒。
- 避免焊劑充滿印刷電路板的頂面。請用刷子塗上焊劑，以減少焊劑滲入。

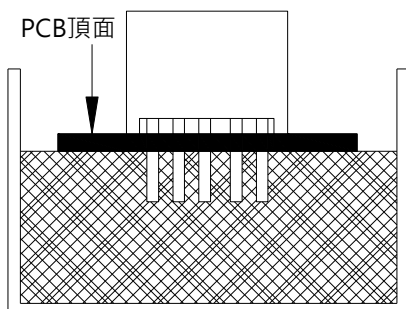

3.清洗

- 如圖所示，清潔焊劑的方式為將開關傾斜80°以下，使用浸泡過溶劑的刷子清潔背面。

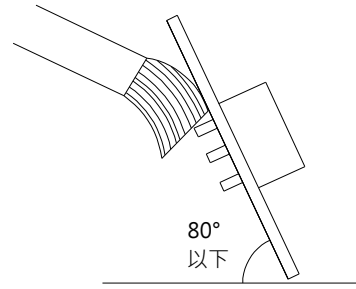

4. PCB端子

- 使用PCB端子型時，PCB端子插入孔設計需大於端子腳0.15~0.60mm之間。
- 請勿對PCB端子施加壓力及撞擊，及避免使開關掉落，可能會導致端子變形斷裂。
- 開關運用於PCB板時，務必使用PCB專用腳型

5.使用烙鐵時

- 請在5秒內最高260°C，PCB 厚度至少超過 1.6 mm以內的條件下焊接。
- 請避免焊接用焊劑或酒精滲入開關內部。
- 焊接時及焊接後約3分鐘內勿對端子施加外力，可能會導致導通或動作不良。

